

Orienteringsmøde d. 24. juni i FAOD kl. 13.00- 16.15

Infomøde om kurset torsdag d 5 august kl 16.30

Kursusstart (seance 1) torsdag d. 19. august kl. 16.30

I denne lille præsentation gives en oversigt over seancerne og de tutorials, der danner grundlaget for kurset



Arkitektskolen Aarhus
Per Kortegaard lektor Emeritus
Juni 2021

1. seance

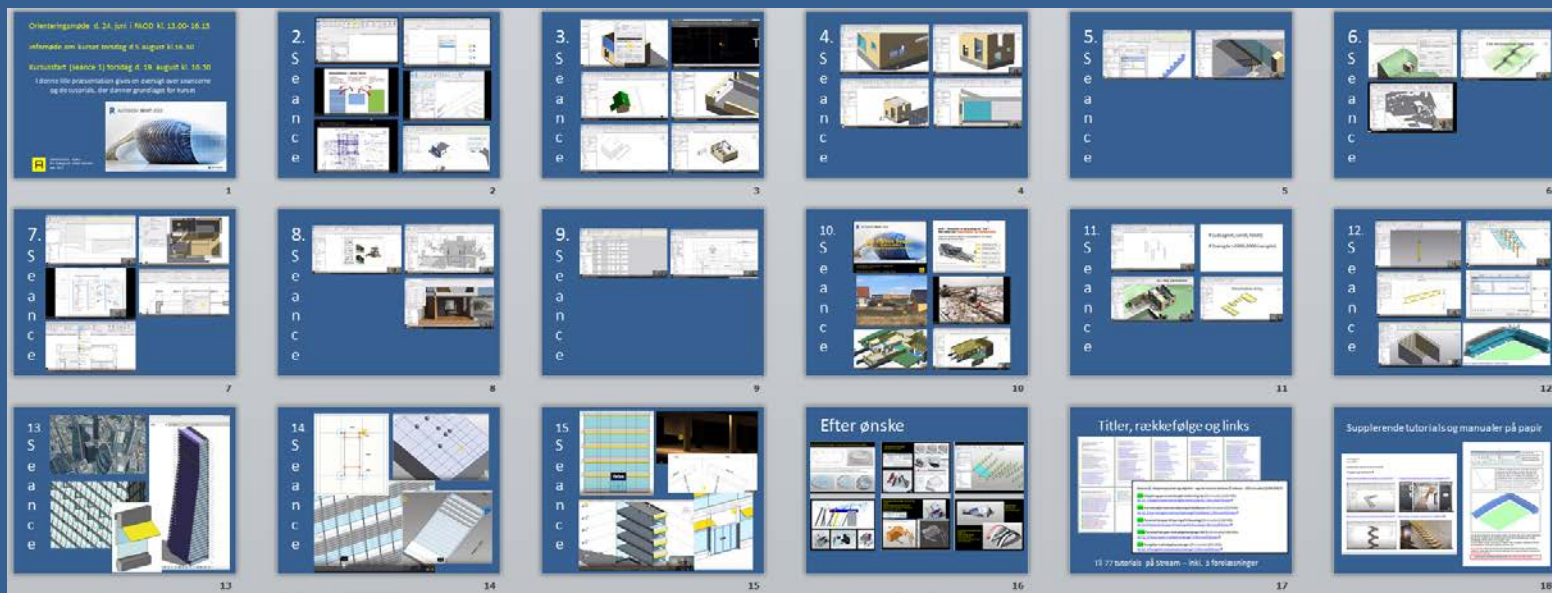

I alt:

- 15 seancer – 15 vejledningsmøder
- 74 tutorials og ugentlige vejledningsmøder
- 3 forelæsninger
- Individuel vejledning og hjælp
- Supplerende tutorials og manualer på papir
- Indlæg fra tegnestuer

2. scene

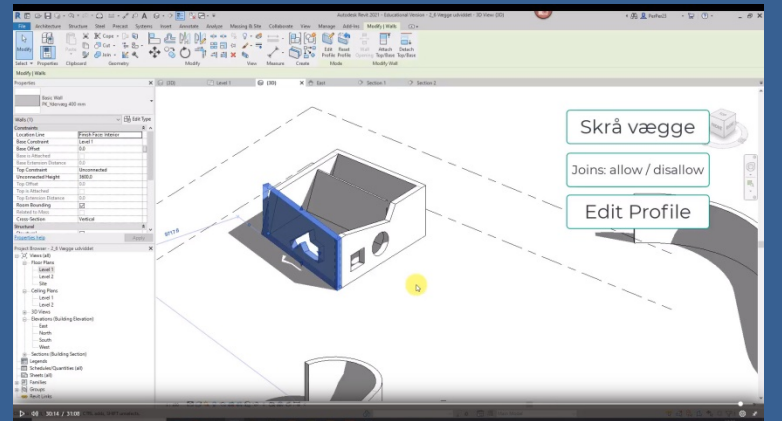
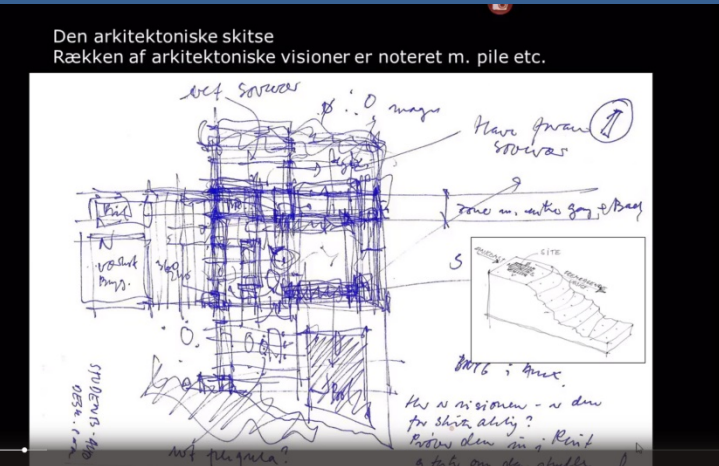
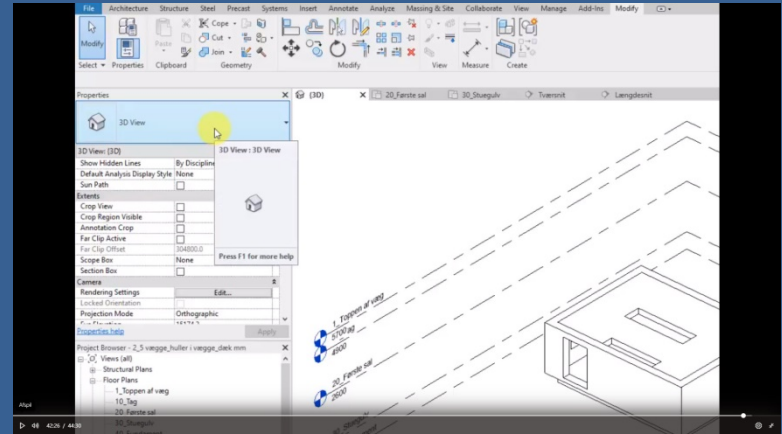
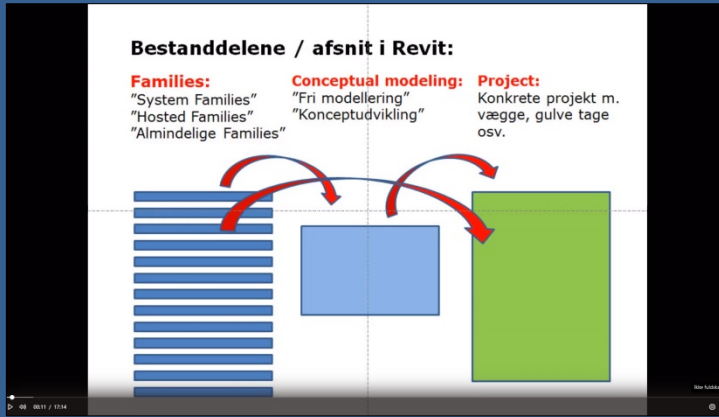
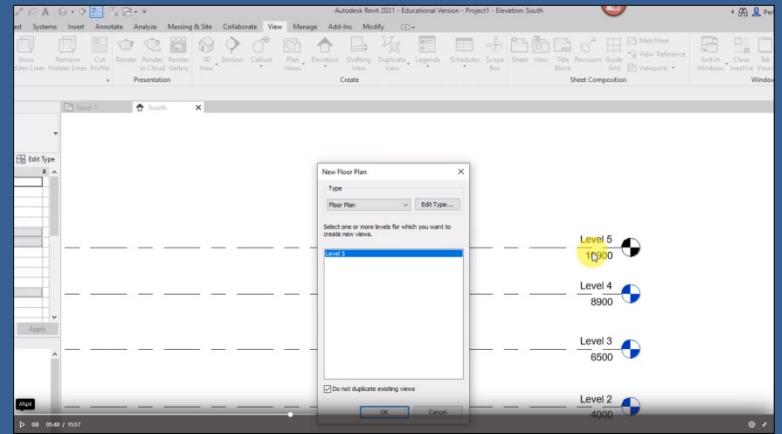
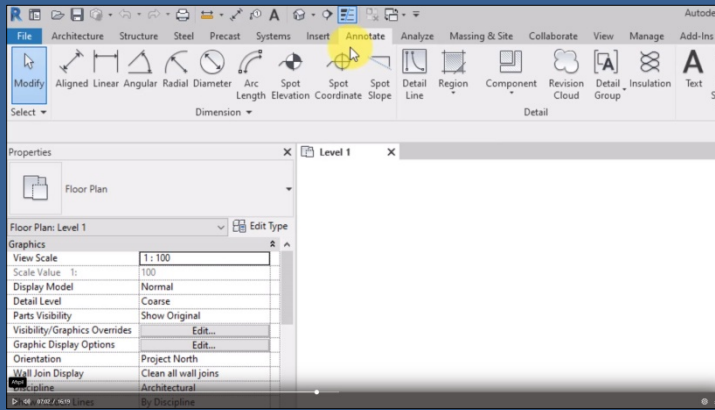

3. S e a n c e

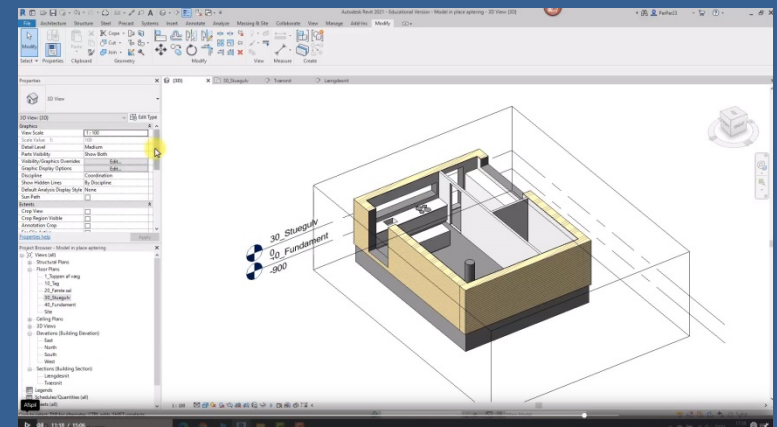
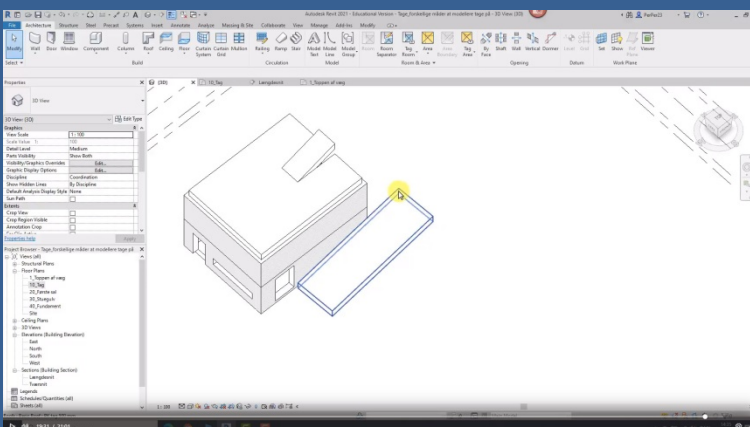
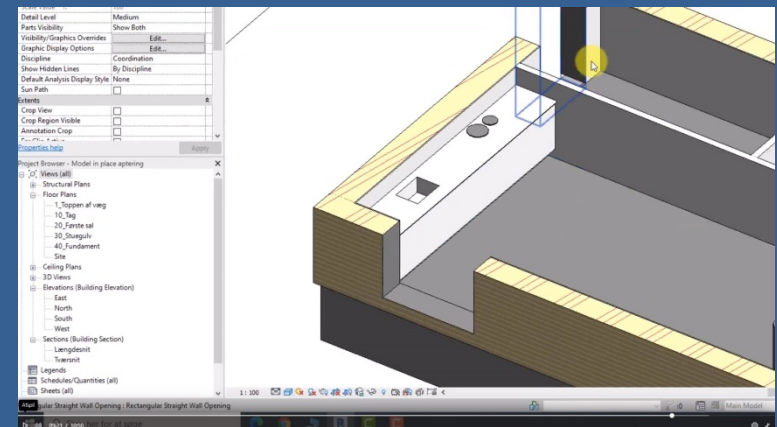
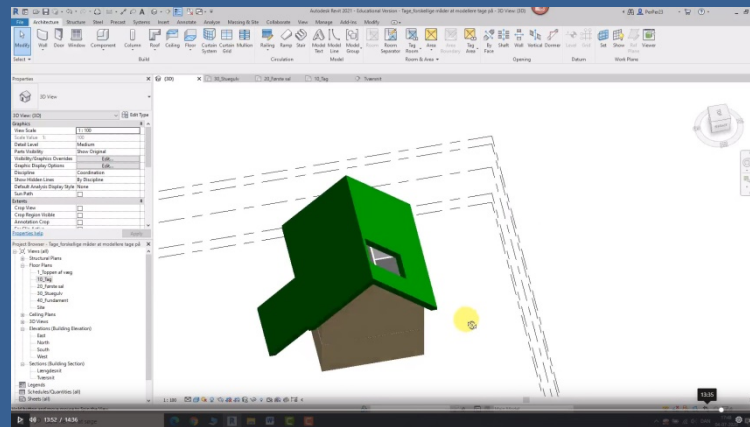
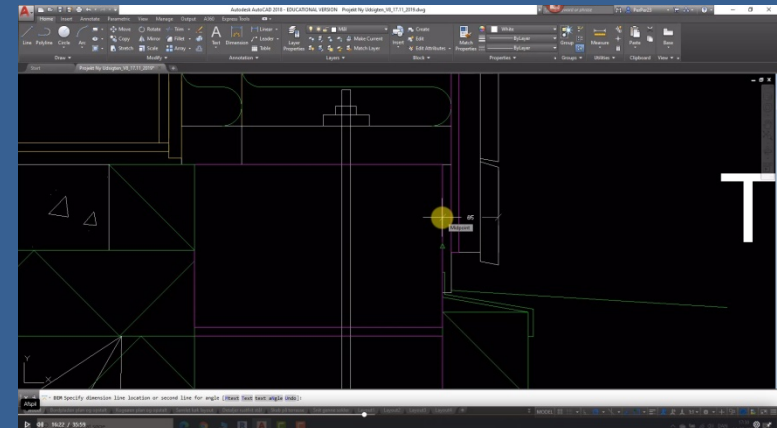
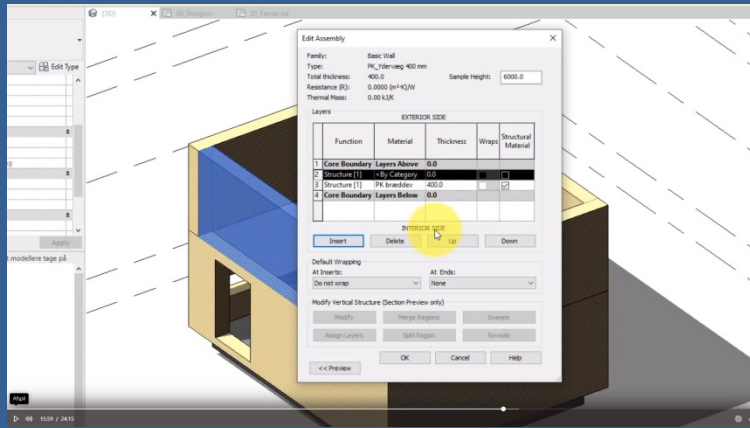

4. scene

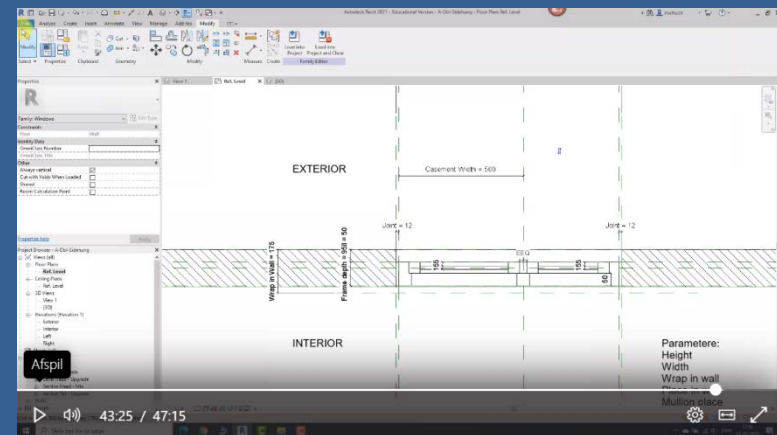
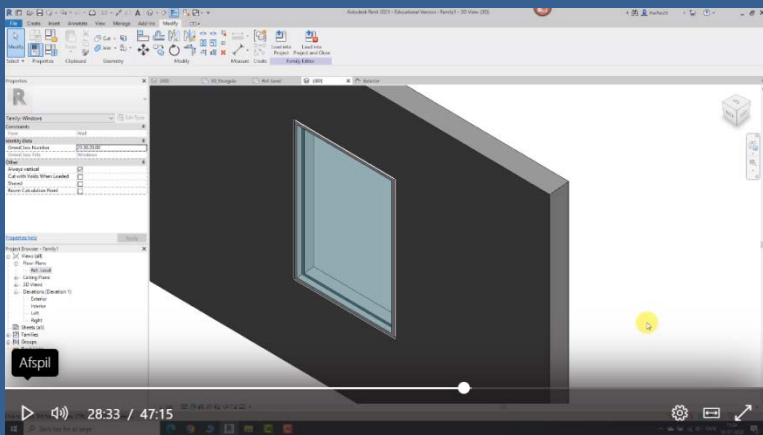
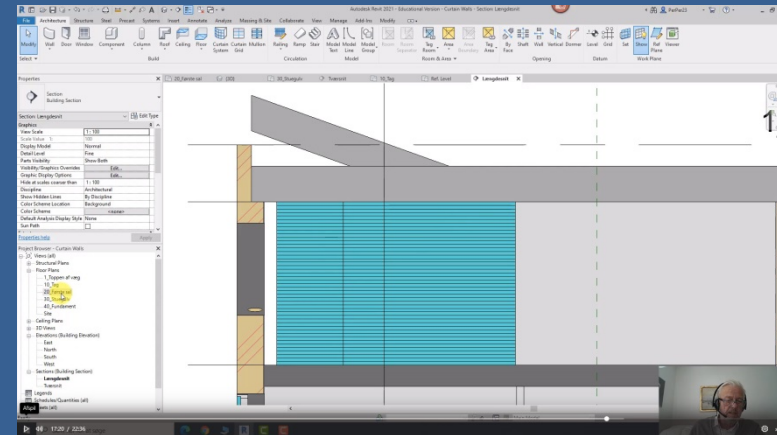
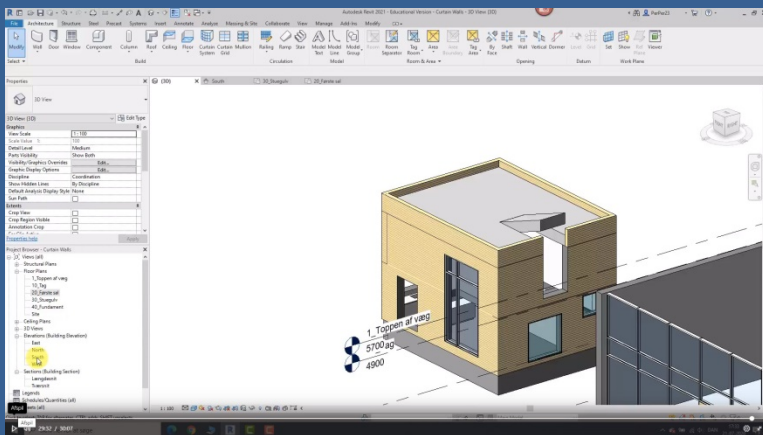
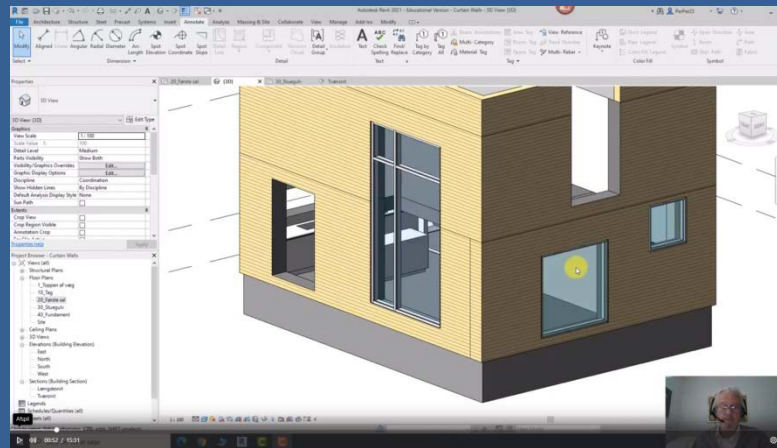
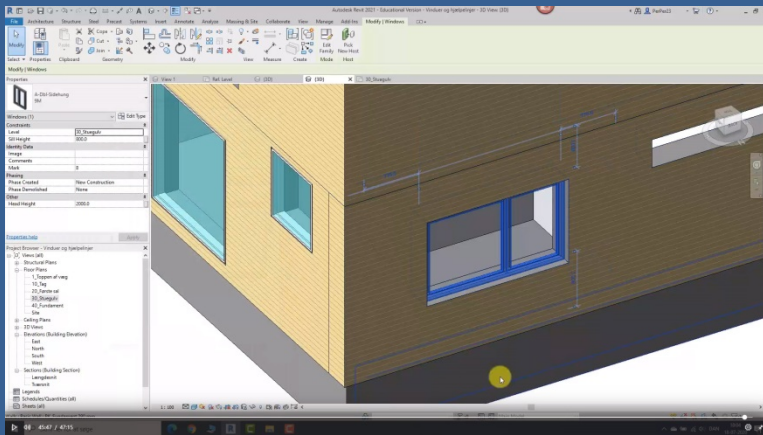

5.5. staircase

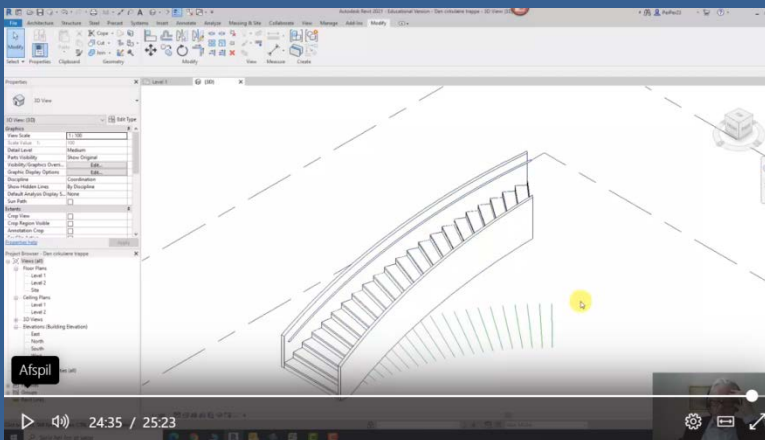
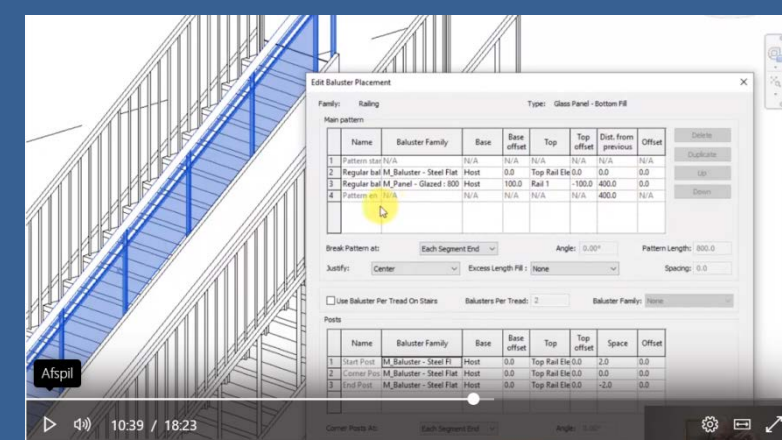
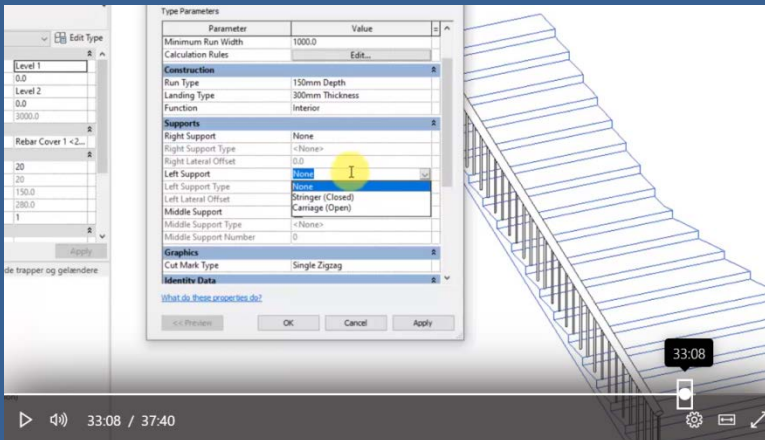
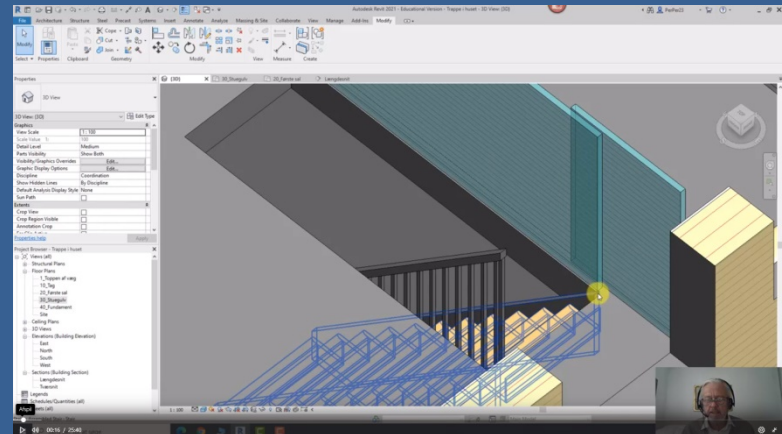
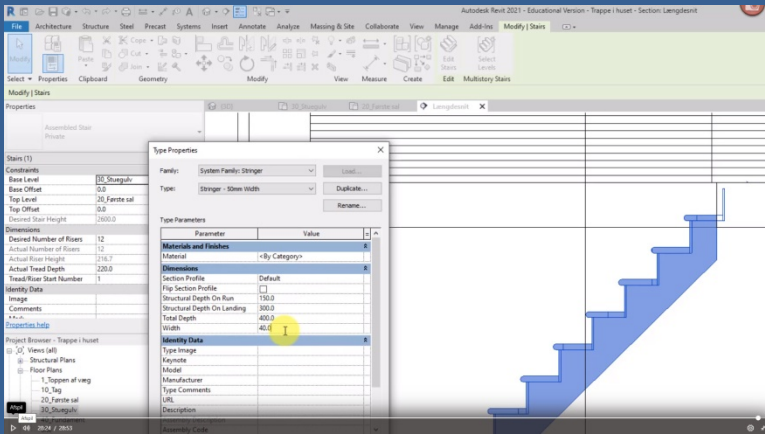

6. s e a n c e

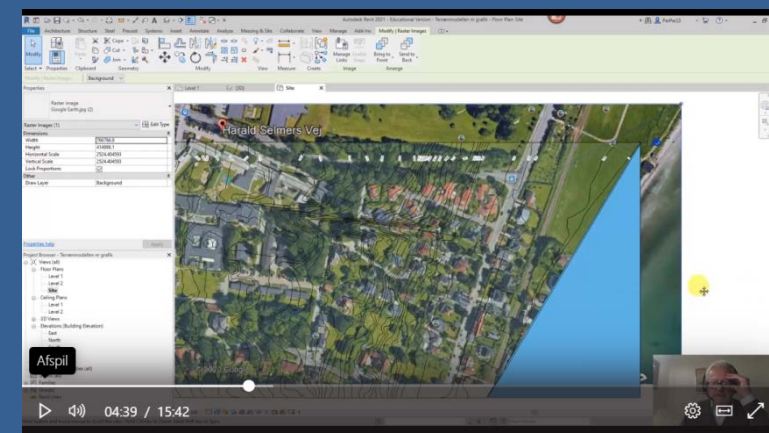
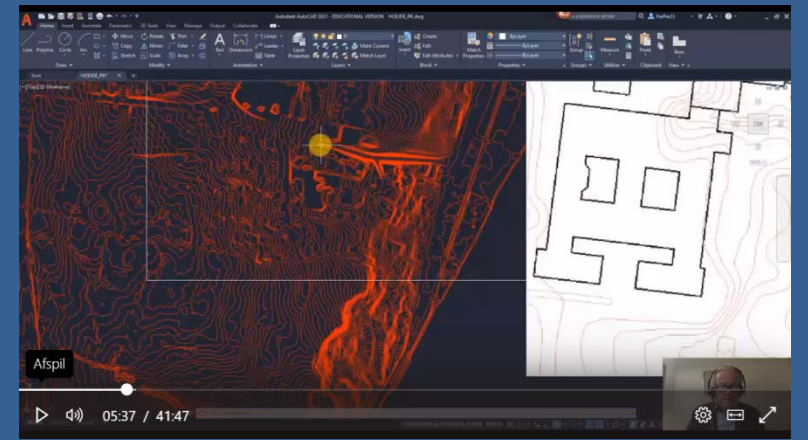
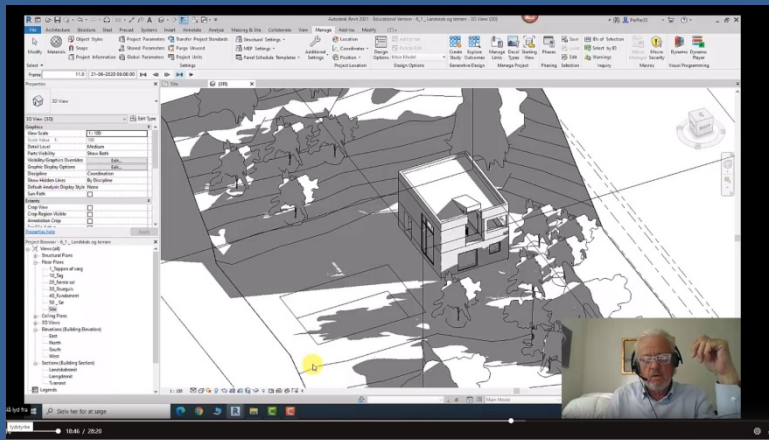
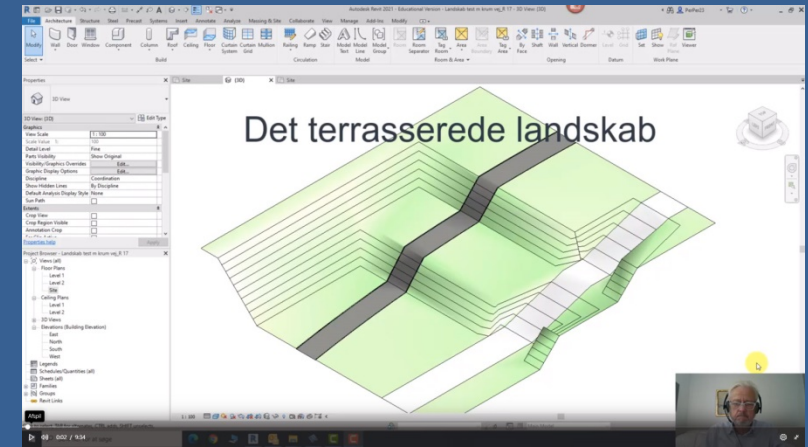
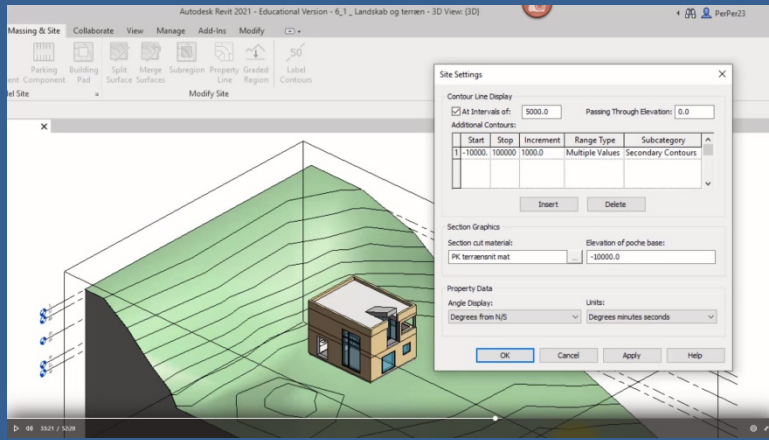

7. scene

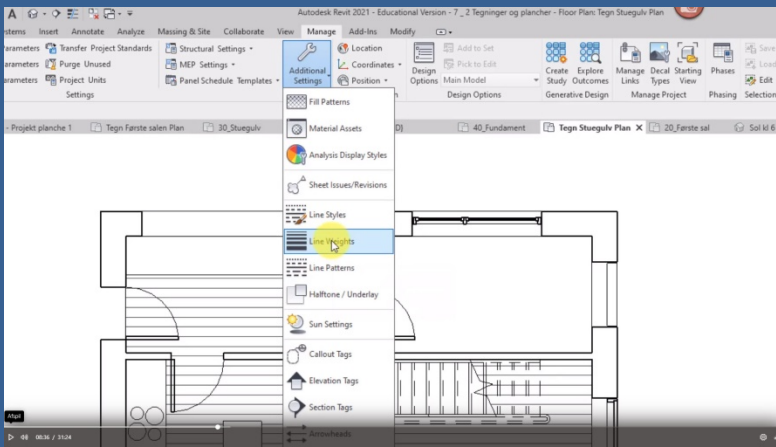
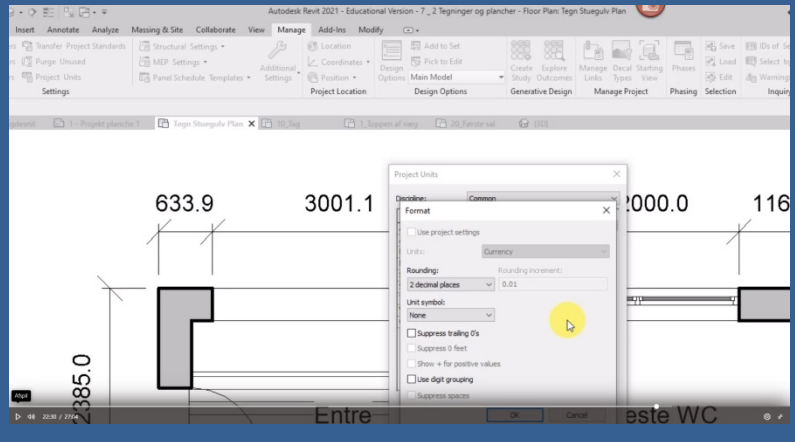
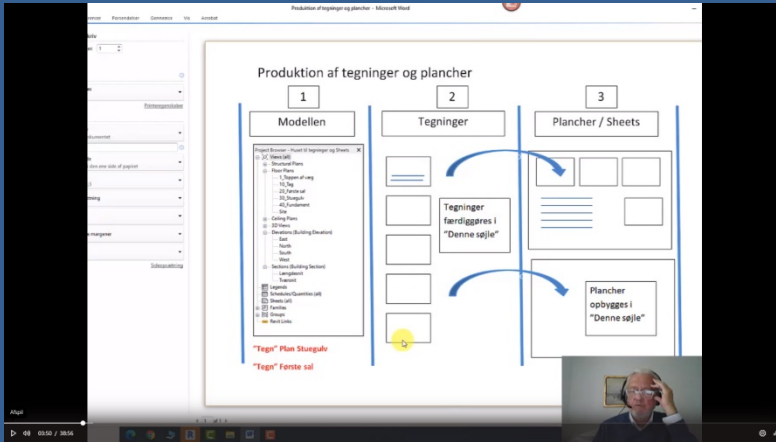
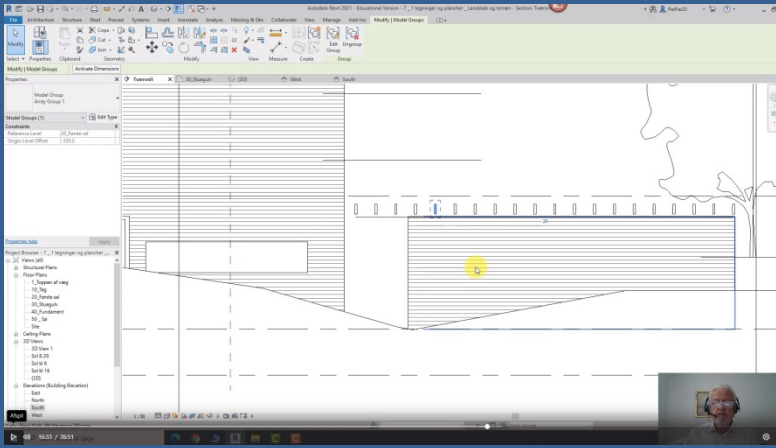

8. scene

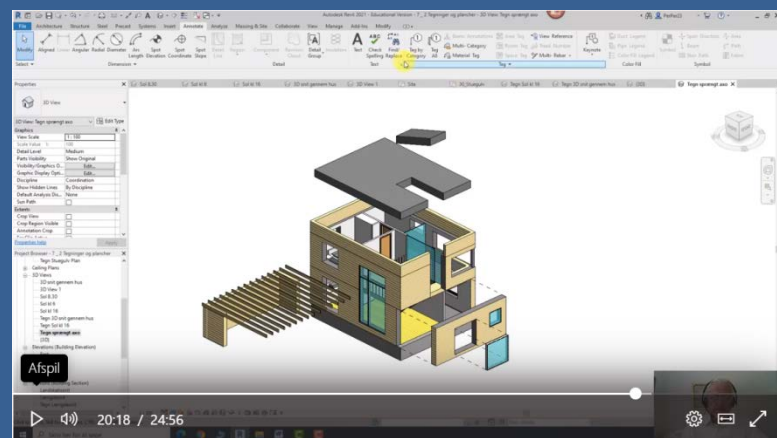
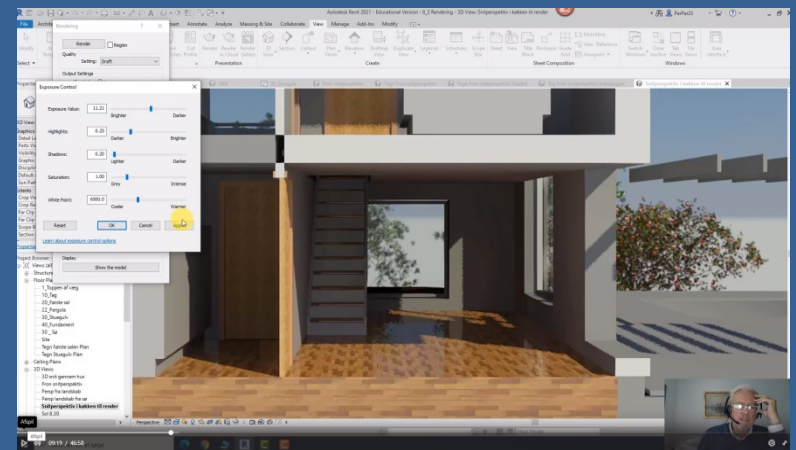
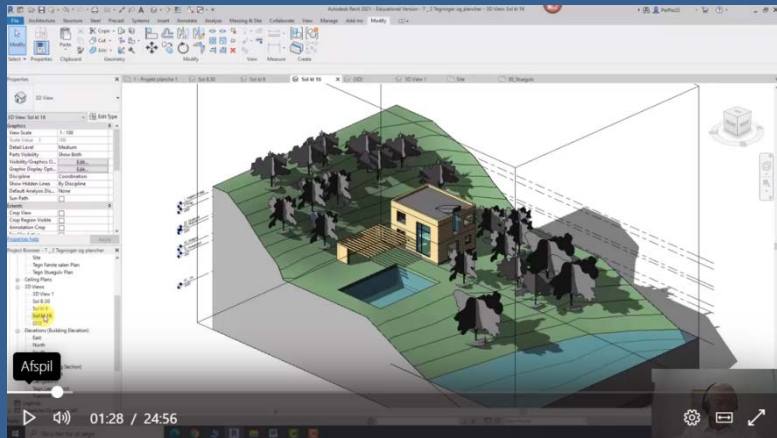
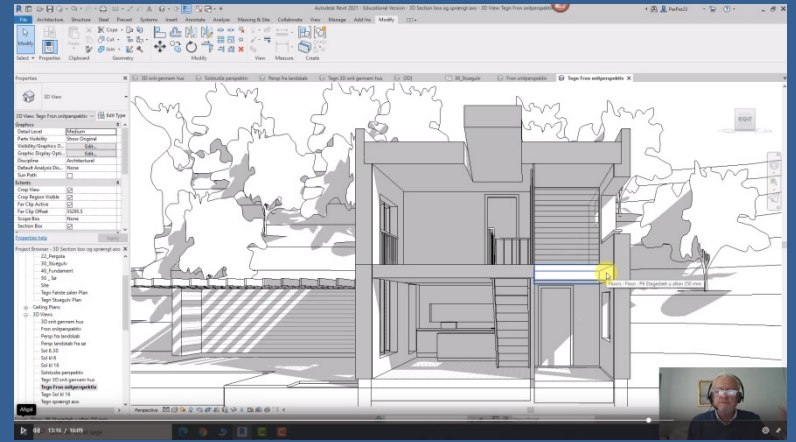
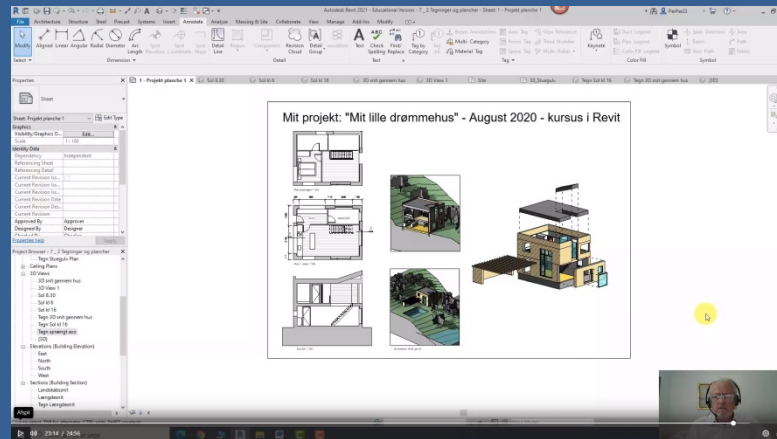

g. s e a n c e

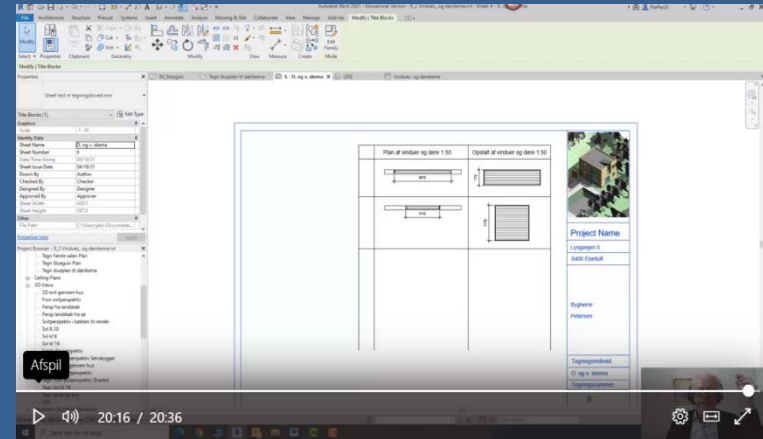
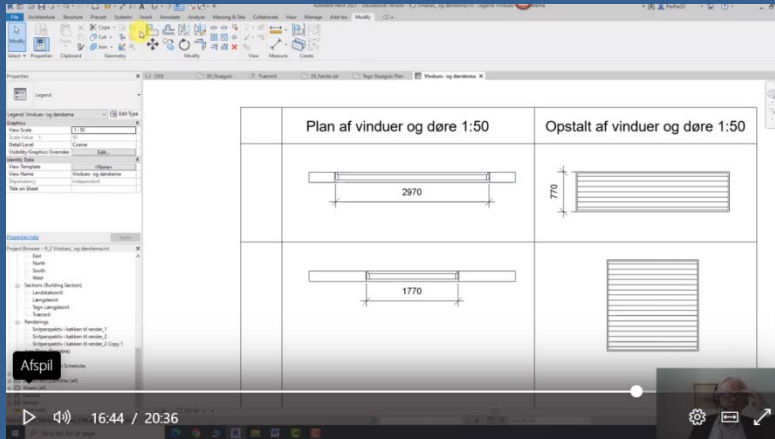
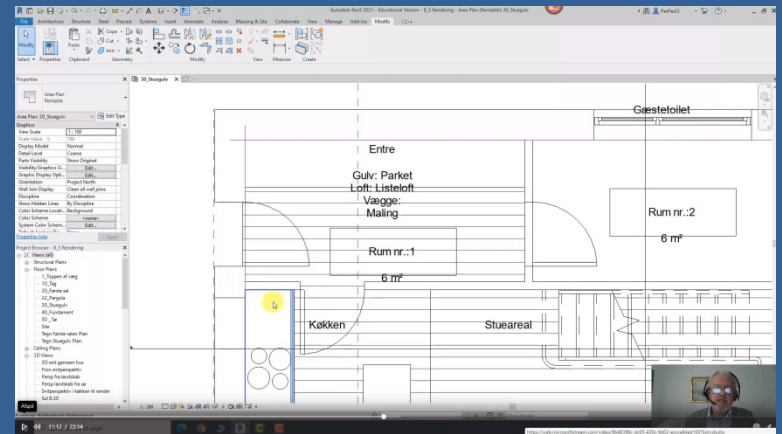
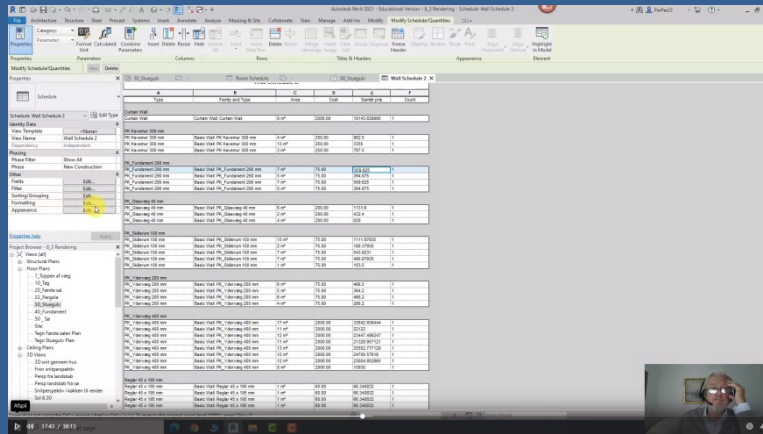

10. Seance

AUTODESK® REVIT® 2019



Det Digitale Byggeri

Hvad er BIM?
"Building Information Modeling"

Per Kortegaard, Lektor Emeritus - Arkitekt MAA
Arkitektskolen Aarhus

Revit Kursus september – oktober 2020



BIM – Modellen er grundlag for "Alt": Der tales om **Fagmodeller** og **Fællesmodel**

Data fra modellen (**BIM**) er grundlaget for en række analyser og simuleringer:



- Udveksling via IFC
- Kollisionskontrol
- Mængder / økonomi
- Energi / sol / vind
- Statik / stabilitet mm.
- HVAC

DIGITAL DESIGN PLATFORM - BIM

C. P. Møller has contributed to defining how the industry uses BIM as a tool. Back in 2004, we already used BIM in the creation of the new Århus University Hospital in Østbø. We have been active on the Danish development project called "The Digital Building". Today, all of our projects are BIM projects, and all of our project managers work according to this method.

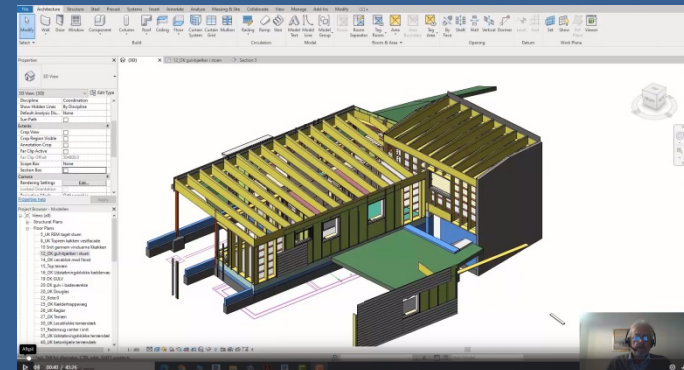
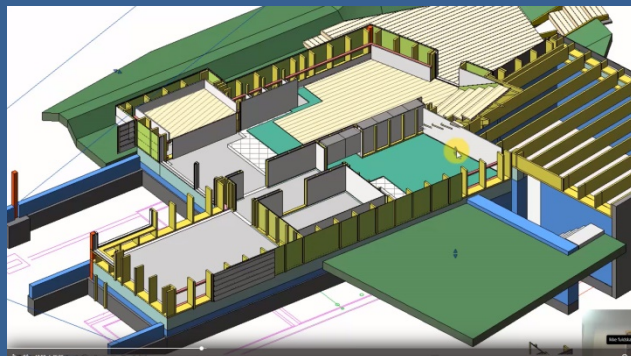

11. S e a n c e

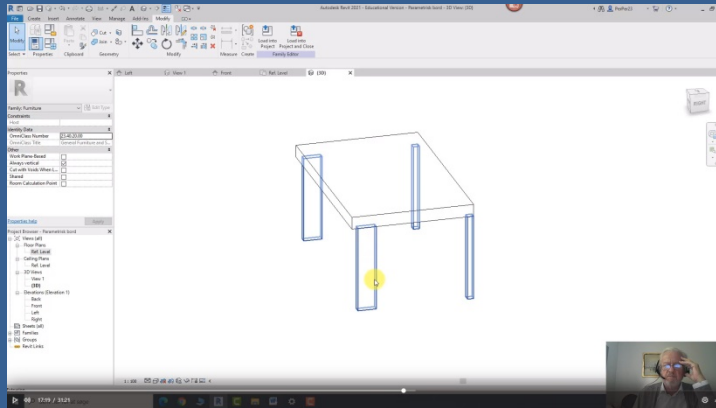

If (udsagnet, sandt, falskt)

If (Længde > 2000, 2000, Længde)

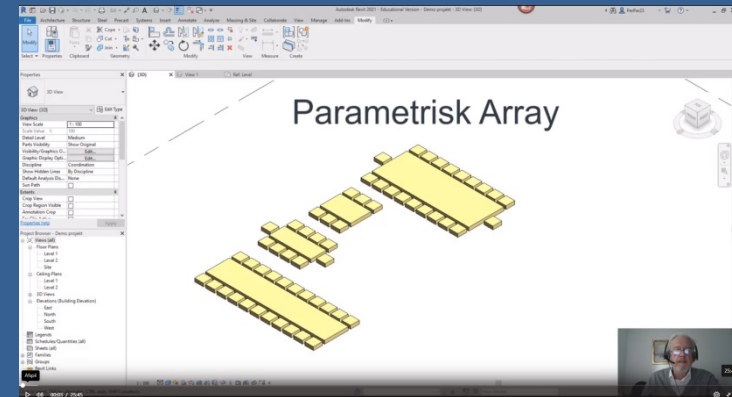
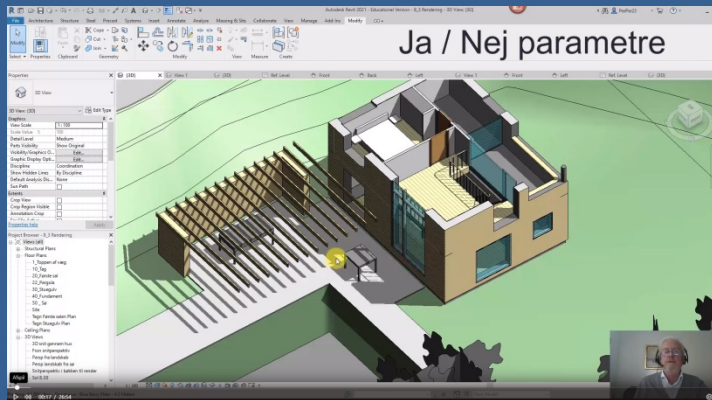

12. Seance

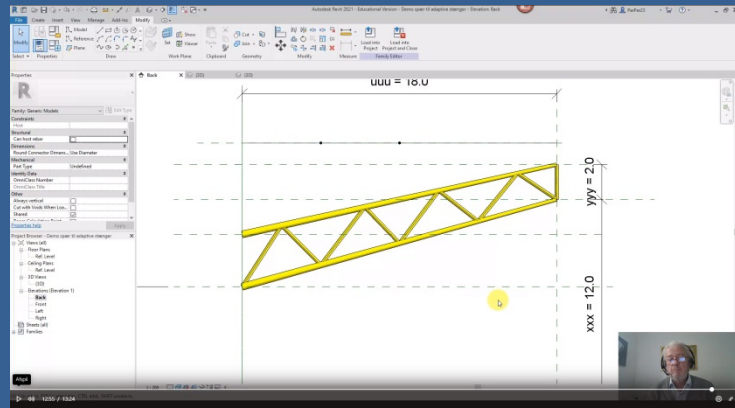
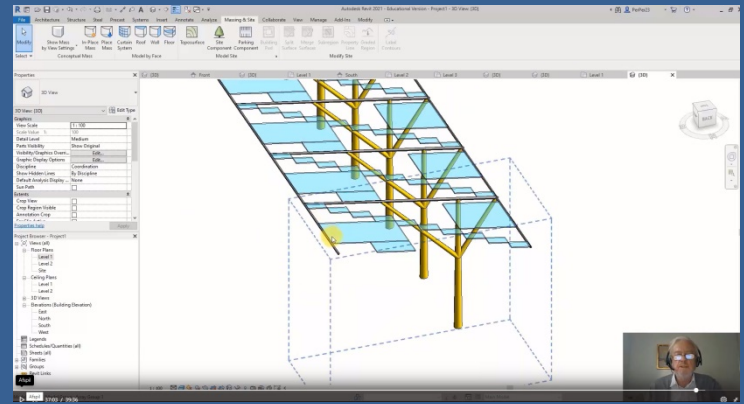
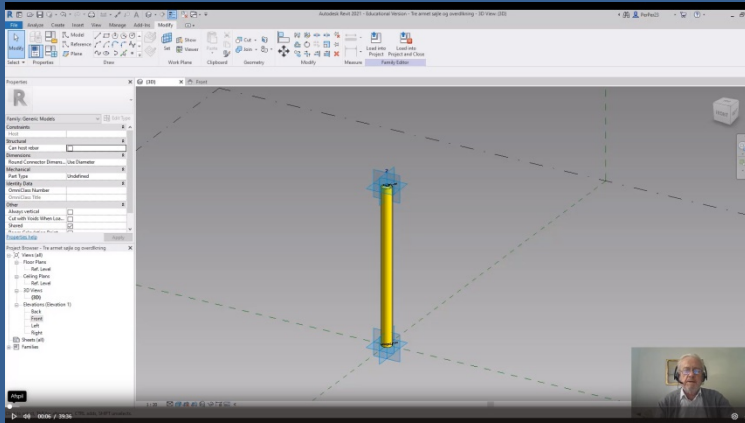

Parameter	Value	Formula	Lock
Constraints			
Default Elevation	0.0		<input type="checkbox"/>
Dimensions			
Børnely	50.0		<input type="checkbox"/>
Bredde (default)	900.0		<input type="checkbox"/>
Højde (default)	720.0		<input type="checkbox"/>
Længde (default)	1800.0	= if (sæt Længde her>2000,2000)	<input type="checkbox"/>
bordpladetykkelse (default)	200.0		<input type="checkbox"/>
sæt Længde her (default)	1500.0		<input type="checkbox"/>
Identity Data			

Manage Lookup Tables

OK Cancel Apply

[How do I manage family types?](#)

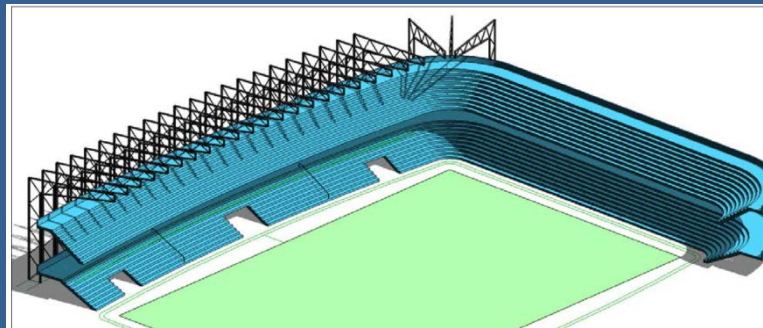
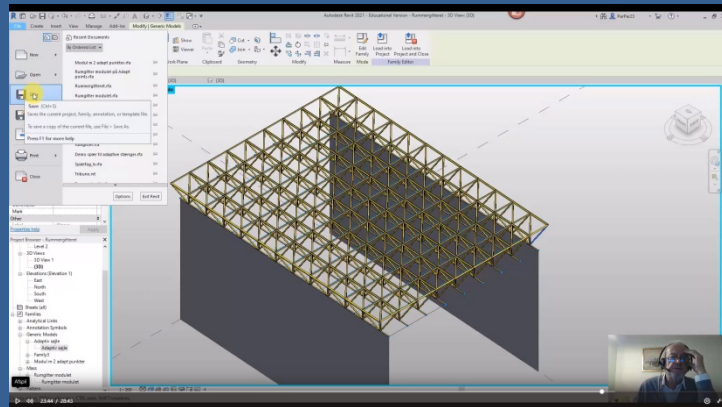

Og her er spærerne blevet opdateret i stadionmodellen.

13.
S
e
a
n
c
e

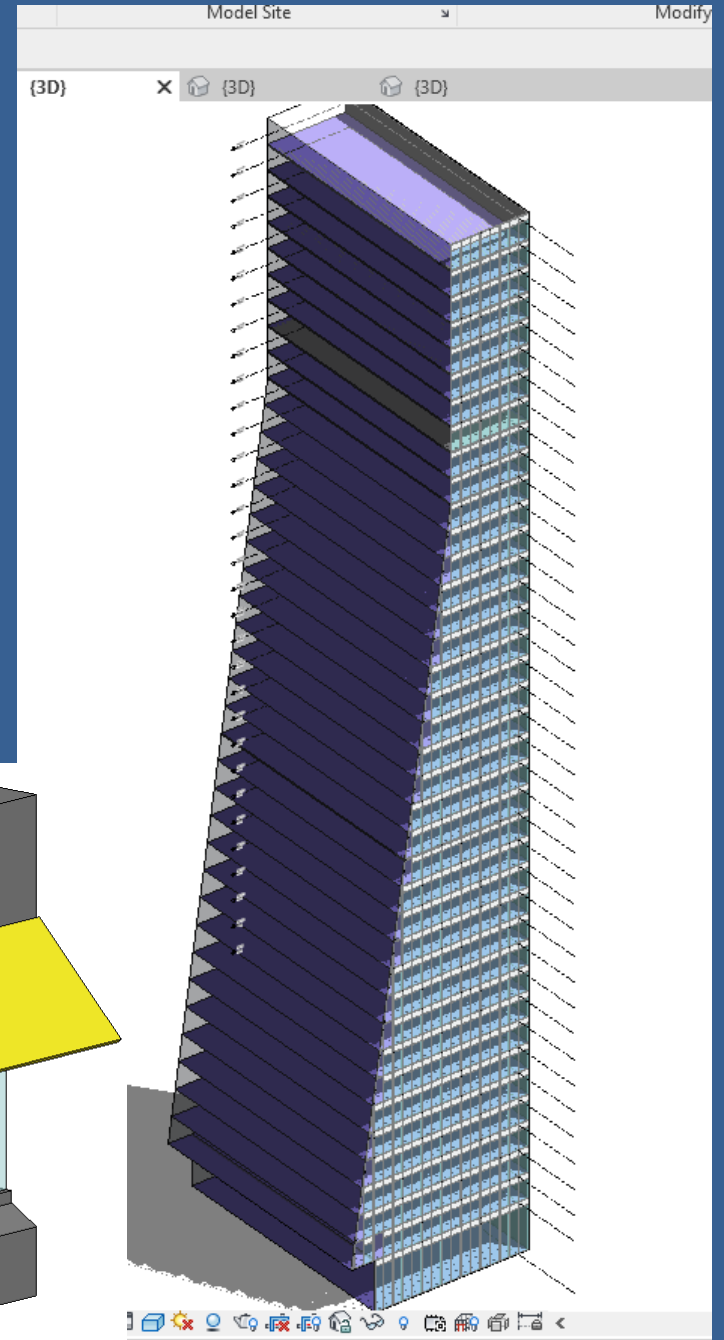
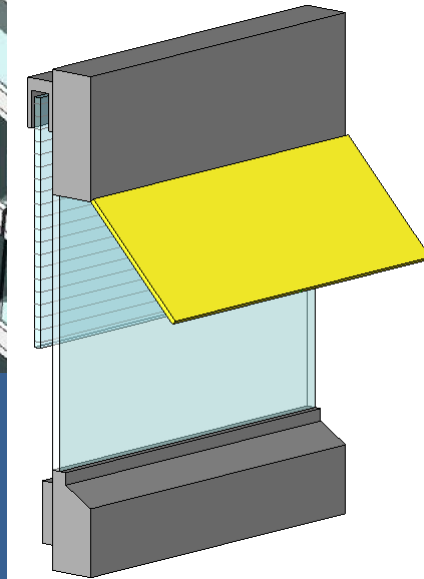
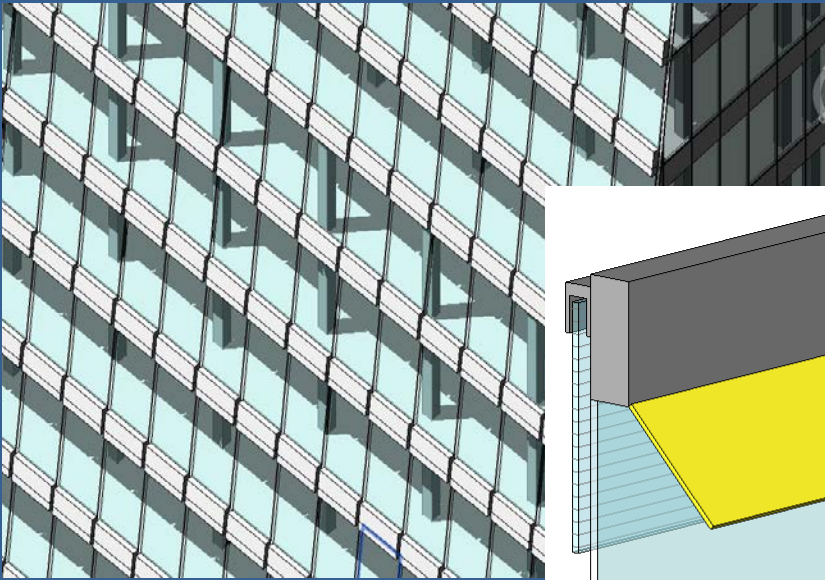

14. S e a n c e

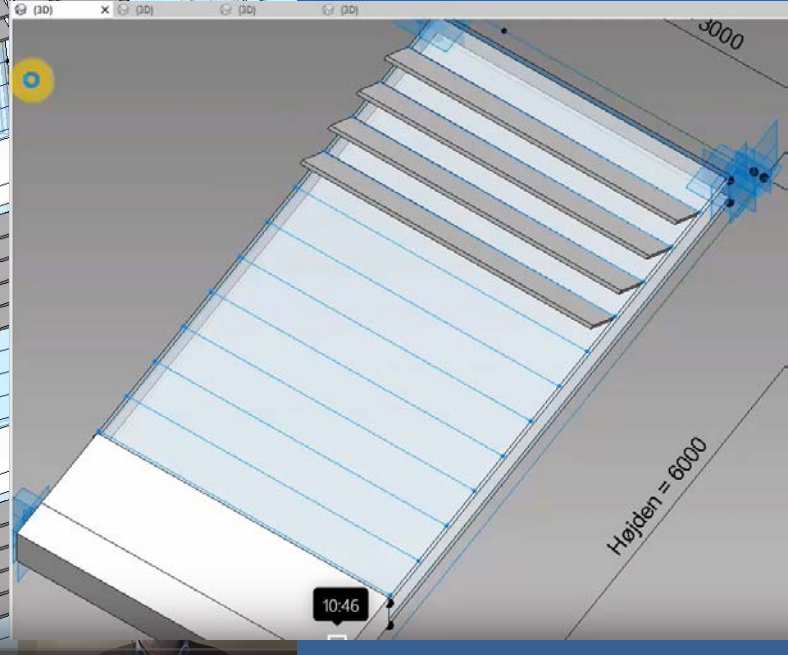
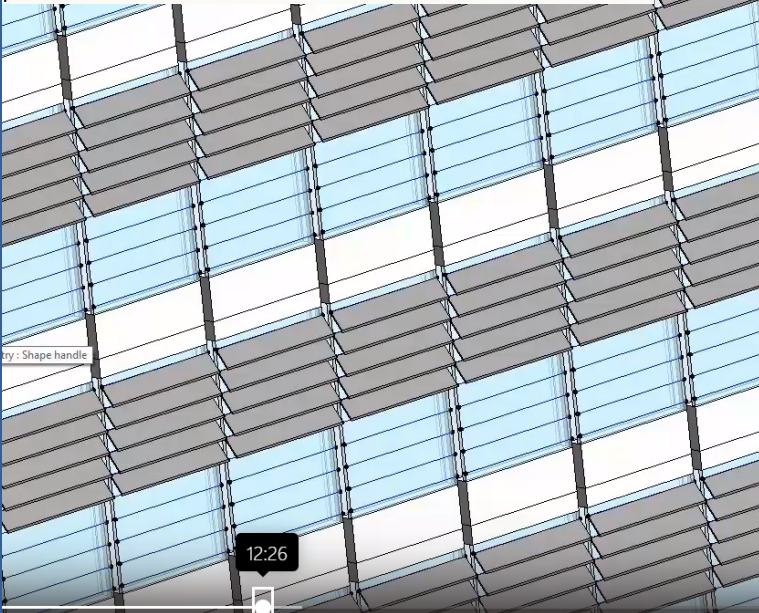
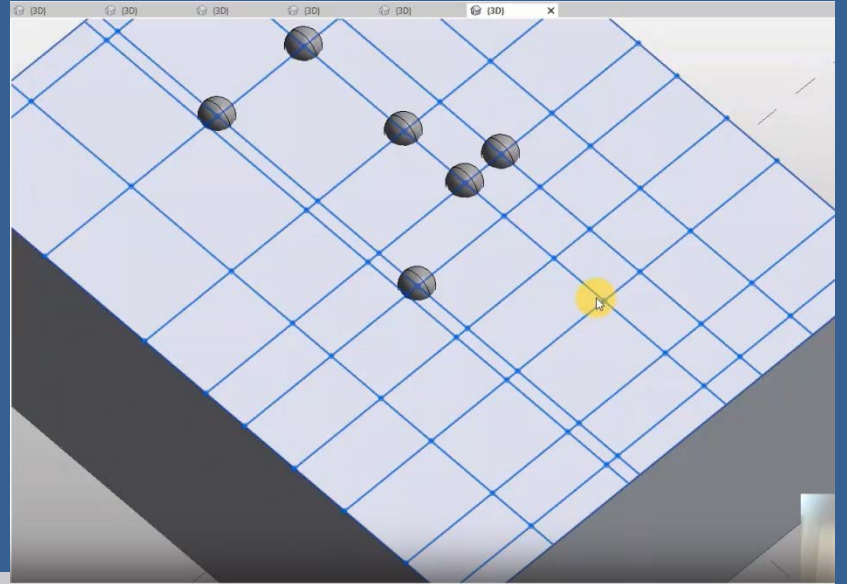
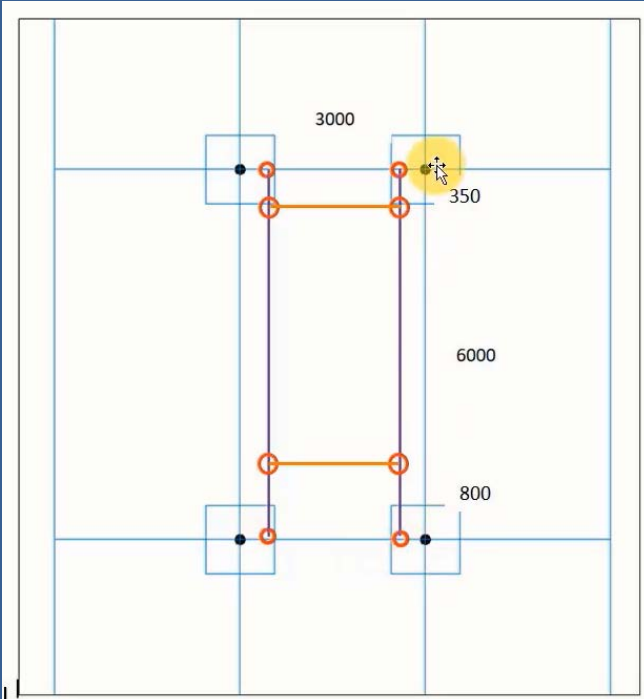

15.
S
e
a
n
c
e

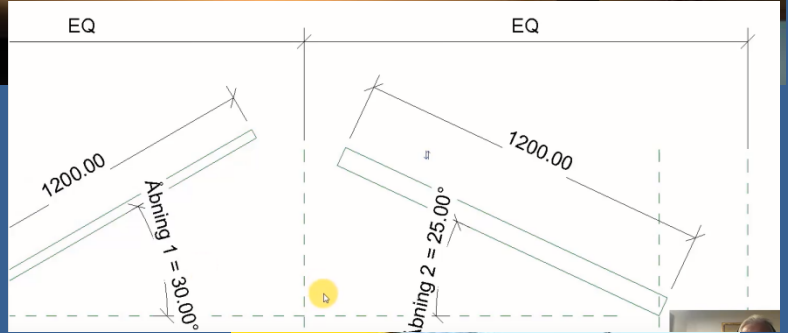
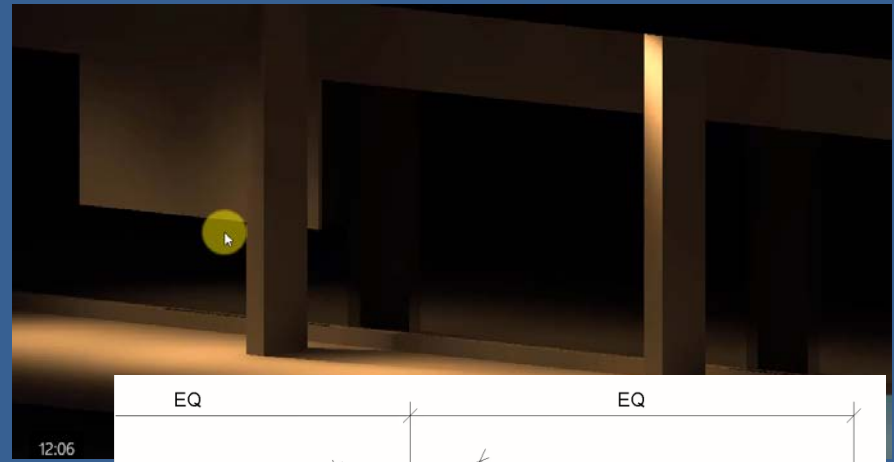
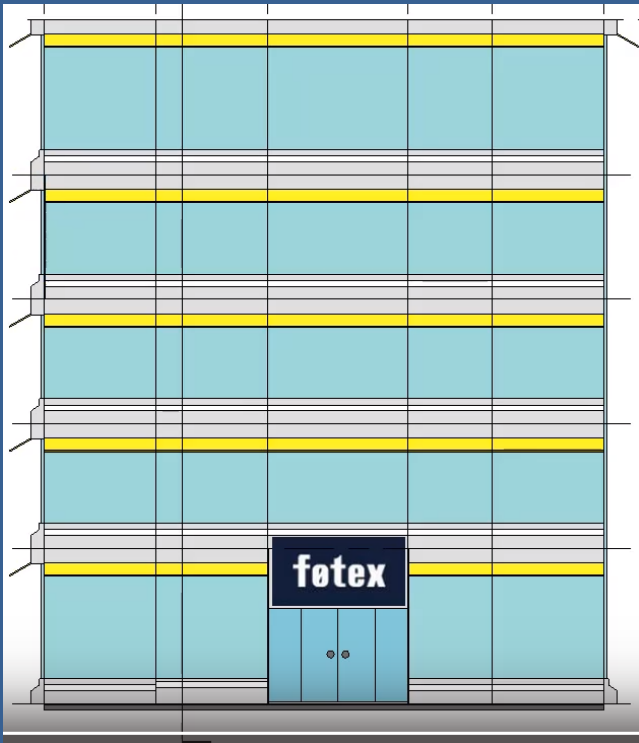

Efter ønske

Et eksempel fra manualen – kunne være starten på en pavillon

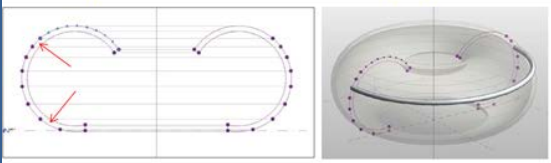

As we add points to the divided point collection of the 9 cords move – so the cords get smaller and smaller ????
Then it is better to use the Divide Surface tool and snap Splines Through Points to the knots
Here with a ref. Spline through Points with a swept circle and with a pattern with out and with shadows

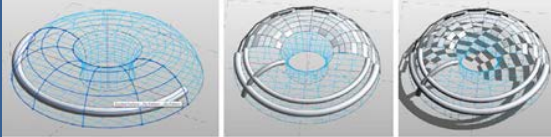

Eksempler på modeller på vej til 3D Prints

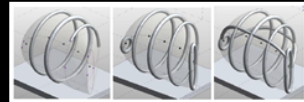
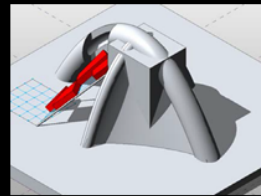
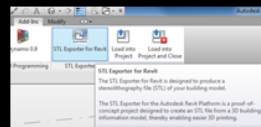

The top of the bottom is lifted and the "Cut Geometry" is used – in other cases use Void Form

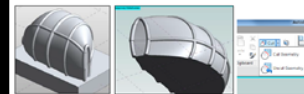

Here in the Project environment (2017), it is in Modeling and Site tab – and "Show Mass Form and Floor" is active!

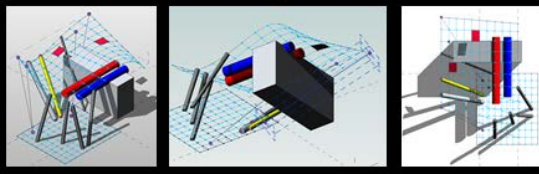
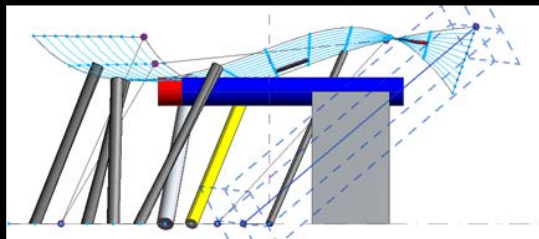
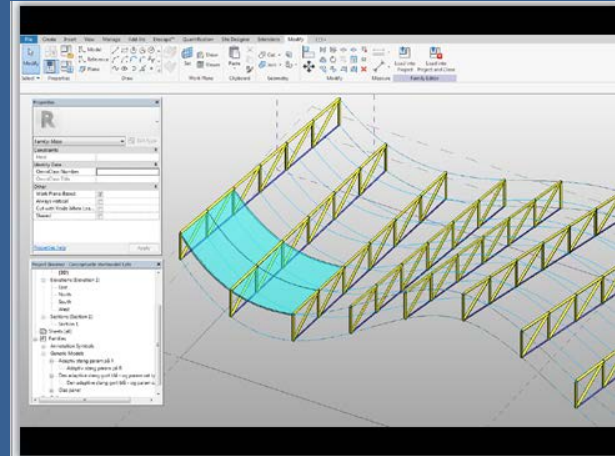
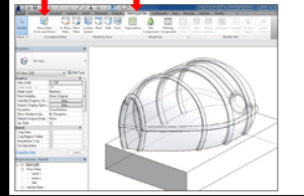

Eksempler på modeller på vej til 3D Prints
Eksporert ud fra Revit til STL
Åbnet i Net Fab eller i MeshMixer
(Autodesk's eget sw)

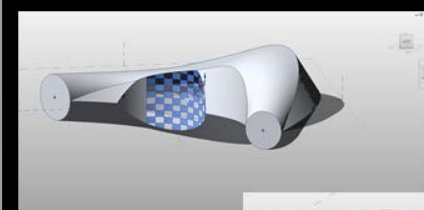
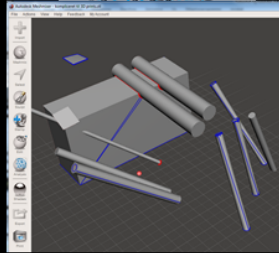
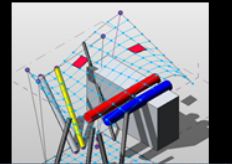
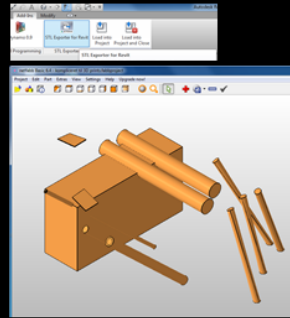

Bananhuset:
Dette er en:
Blend along path

Geometrisk bestemte buer
Dette er:
Buer swept along
reference lines.
Og divided surfaces med
arrayed panels

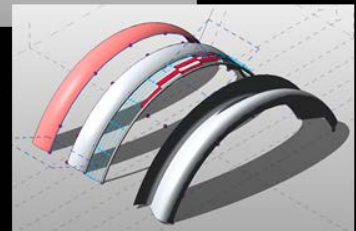

Kalender:
 Informationsmøde
 Kursusopstart
 9 seancer "Basic"
 5 seancer "Advanced"
 16 seancer i alt
 Fra august til december

"Hurtigløberne" kan
 forkorte kursusperioden
 ved koncentreret indsats

Kalender		
Informationsmøde:		
Torsdag d. 5. august kl. 16.30:	Information, spørgsmål og afklaring af praktiske forhold	Informationsmøde 1 tutorial
Kursusopstart Seance 1:		
Torsdag d. 19. august kl. 16.30:	Velkomst	Opstartsmøde
Er der hul til Stream, virker softwaren og start på tutorial:		Afklaring: klar til start
Basic:		
Torsdag d. 26. august kl. 16.30:	Brugerinterfacet, struktur og opbygningen af Revit	Vejledningsmøde 2: Baggrund: 6 tutorials
Torsdag d. 2. september kl. 16.30:	Færdigmodellering af råhus og begyndende aptering	Vejledningsmøde 3: Baggrund: 6 tutorials
Torsdag d. 9. september 16.30:	Vinduer, døre og Curtain Walls	Vejledningsmøde 4: Baggrund: 4 tutorials
Torsdag d. 16. september kl. 16.30:	Trappetyper, trappen, gelænder, rækværk og "skrå" gulve	Vejledningsmøde 5: Baggrund: 8 tutorials
Torsdag d. 23. september kl. 16.30:	Landskab og terræn - True North og Project North	Vejledningsmøde 6: Baggrund: 5 tutorials
Torsdag d. 30. september kl. 16.30:	Udarbejdelse af tegninger og plancher	Vejledningsmøde 7: Baggrund: 6 tutorials
Torsdag d. 7. oktober kl. 16.30:	3D Visualiseringer og rendering	Vejledningsmøde 8: Baggrund: 3 tutorials
Torsdag d. 14. oktober kl. 16.30:	Scheduels / skemaer og arbejdet hermed	Vejledningsmøde 9: Baggrund: 6 tutorials
Torsdag d. 28. oktober kl. 16.30:	3 Forelæsninger og gennemgange	Vejledningsmøde 10: 3grund: 3 forelæsninger
Advanced:		
Onsdag d. 4. november kl. 16.30:	Parametri og Parametrisk modellering	Vejledningsmøde 11: Baggrund: 5 tutorials
Torsdag d. 11. november kl. 16.30:	Adaptive punkter og objekter - og store konstruktioner	Vejledningsmøde 12: Baggrund: 7 tutorials
Torsdag d. 18. november kl. 16.30:	Conceptual modeling - en skyskraber	Vejledningsmøde 13: Baggrund: 7 tutorials
Torsdag d. 25. november kl. 16.30:	Avancerede facadeløsninger og avancerede facadepaneler	Vejledningsmøde 14: Baggrund: 6 tutorials
Torsdag d. 2. december kl. 16.30:	Avancerede Curtain Wall løsninger	Vejledningsmøde 15: Baggrund: 6 tutorials

Titler, rækkefølge og links

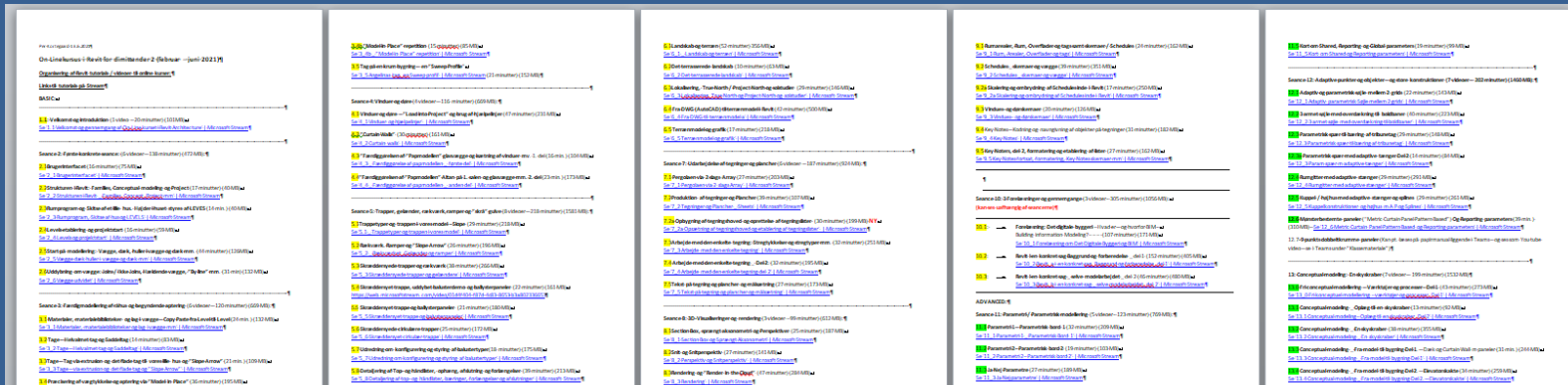

Seance 12: Adaptive punkter og objekter – og store konstruktioner (7 videoer – 202 minutter) (1460-MB) ¶

[12.1 Adaptive og parametriske søjle mellem 2 grids \(22 minutter\) \(143-MB\) ¶](#)

[Se '12 1 Adaptive parametriske søjle mellem 2 grids' | Microsoft Stream ¶](#)

[12.2 3-armet søjle med overdækning til boldbaner \(40 minutter\) \(223-MB\) ¶](#)

[Se '12 2 3-armet søjle med overdækning til boldbaner' | Microsoft Stream ¶](#)

[12.3 Parametriske spær til bæring af tribunetag \(29 minutter\) \(148-MB\) ¶](#)

[Se '12.3 Parametriske spær til bæring af tribunetag' | Microsoft Stream ¶](#)

[12.3a Parametriske spær med adaptive tænger Del 2 \(14 minutter\) \(84-MB\) ¶](#)

[Se '12 3 Parametriske spær med adaptive tænger' | Microsoft Stream ¶](#)

[12.4 Rumgitter med adaptive stænger \(29 minutter\) \(291-MB\) ¶](#)

[Se '12 4 Rumgitter med adaptive stænger' | Microsoft Stream ¶](#)

Til 77 tutorials på Stream – inkl. 3 forelæsninger

Supplerende tutorials og manualer på papir

Per-Kortegaard⁺
12.11.2020

Supplerende tutorials til kursus i Revit

Trapper og rækværk:

<https://www.youtube.com/watch?v=LKrbjEGJF8Y> <https://www.youtube.com/watch?v=73a8gMP6DY>

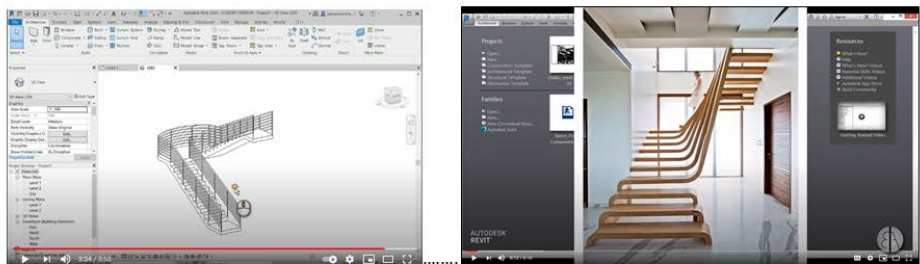

<https://www.youtube.com/watch?v=RlqDKny0538> <https://www.youtube.com/watch?v=1tRxtteLQid>

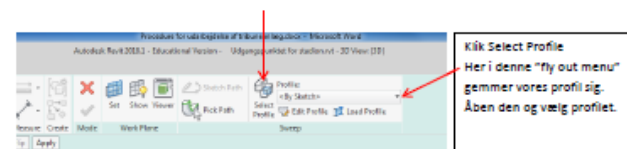
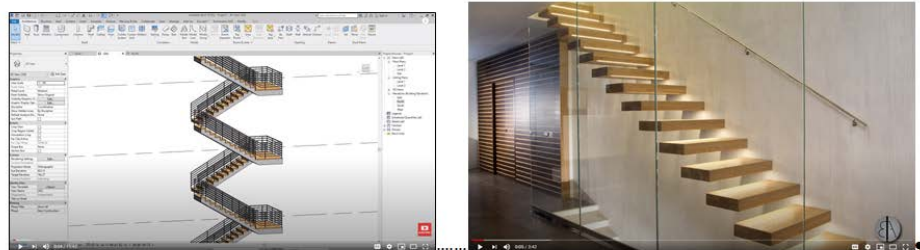

Profilet har nu placeret sig med 0 i 0 så at sige. Som det ses, er der afstand fra sweep-linjen til forkanten af profilet. Denne afstand er jo sat som en parameter inde i skabelonen, hvor profilet blev skabt. Nu vil vi sweepe ved at klikke grønt V – og efterfølgende vurdere, om proportioner og placering er gode. Hvis der skal justeres, klikkes på profilet, hvorved knappen "Edit Family" fremkommer – et klik på knappen bringer os tilbage til family editoren, og profilet kan justeres og igen Loades into Project – og "OVERRIDE existing and its parameters".

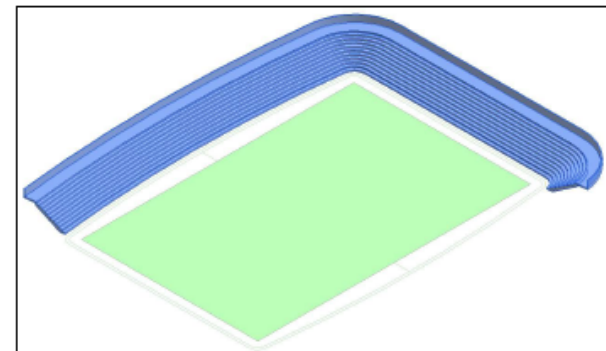

Man skal være utrolig varsom, når man tegner profilen – der må ikke være "huller" mellem linjestykkerne (den skal være "vandtæt" som det udtrykkes) og der må ikke være overskydende linjer. Kort sagt profitlegningen skal være præcis, hel, ren og ingen "huller". Det samme gælder for linjen / eller linjerne der vælges til "Path" for sweepen. Linjestykkerne skal være sammenhængende, må ikke gå forbi hinanden, eller have "huller".

Hvis det ikke virker: tegn de en stor cirkel eller en ret linje og test disse som path. Hvis dette virker er profilen OK, og fejlen ligger i den komplicerede valgte path. Der er mange, der løber ind i problemer her. **Så vær præcis fra starten af!**

Justere profilen til det ønskede, og så skal profilen Copy / Pastes op til en øvre tribune:

Håber at se Jer!



På gensyn!